

CORRECT SEQUENCE OF ELECTRO-INJECTORS

THE INJECTORS BLOCK MUST BE ASSEMBLED IN NUMERICAL SEQUENCE AS
SHOW ON THE PICTURE

EXAMPLE FOR 3 AND 4 CYLINDERS

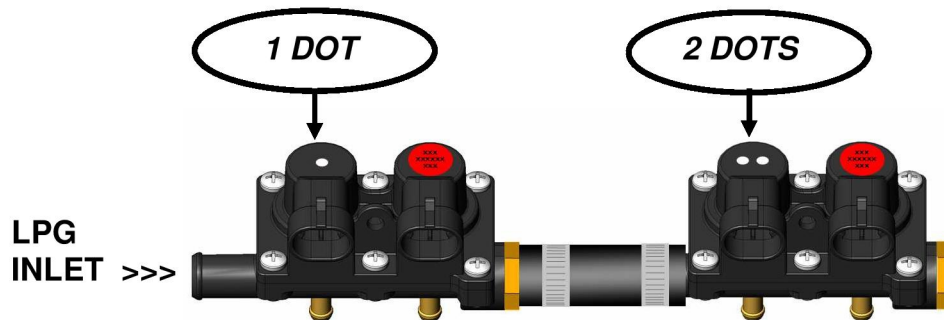

EXAMPLE FOR 5 AND 6 CYLINDERS "LINEAR" TYPE

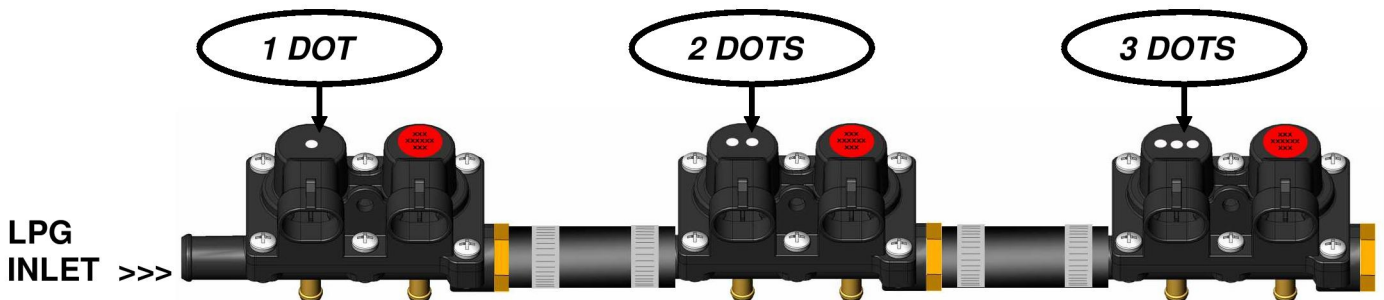

EXAMPLE FOR 6 CYLINDERS "V" TYPE AND 8 CYLINDERS

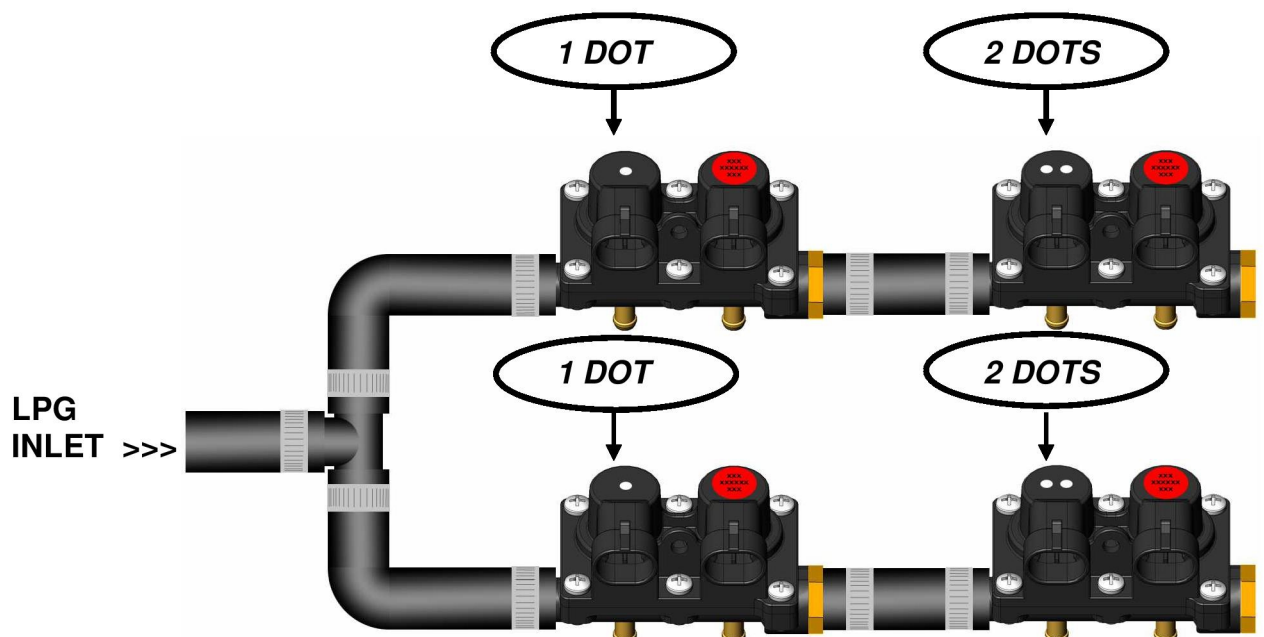

INJECTION KIT SIS 8 CYLINDERS ELECTRICAL SCHEDULE

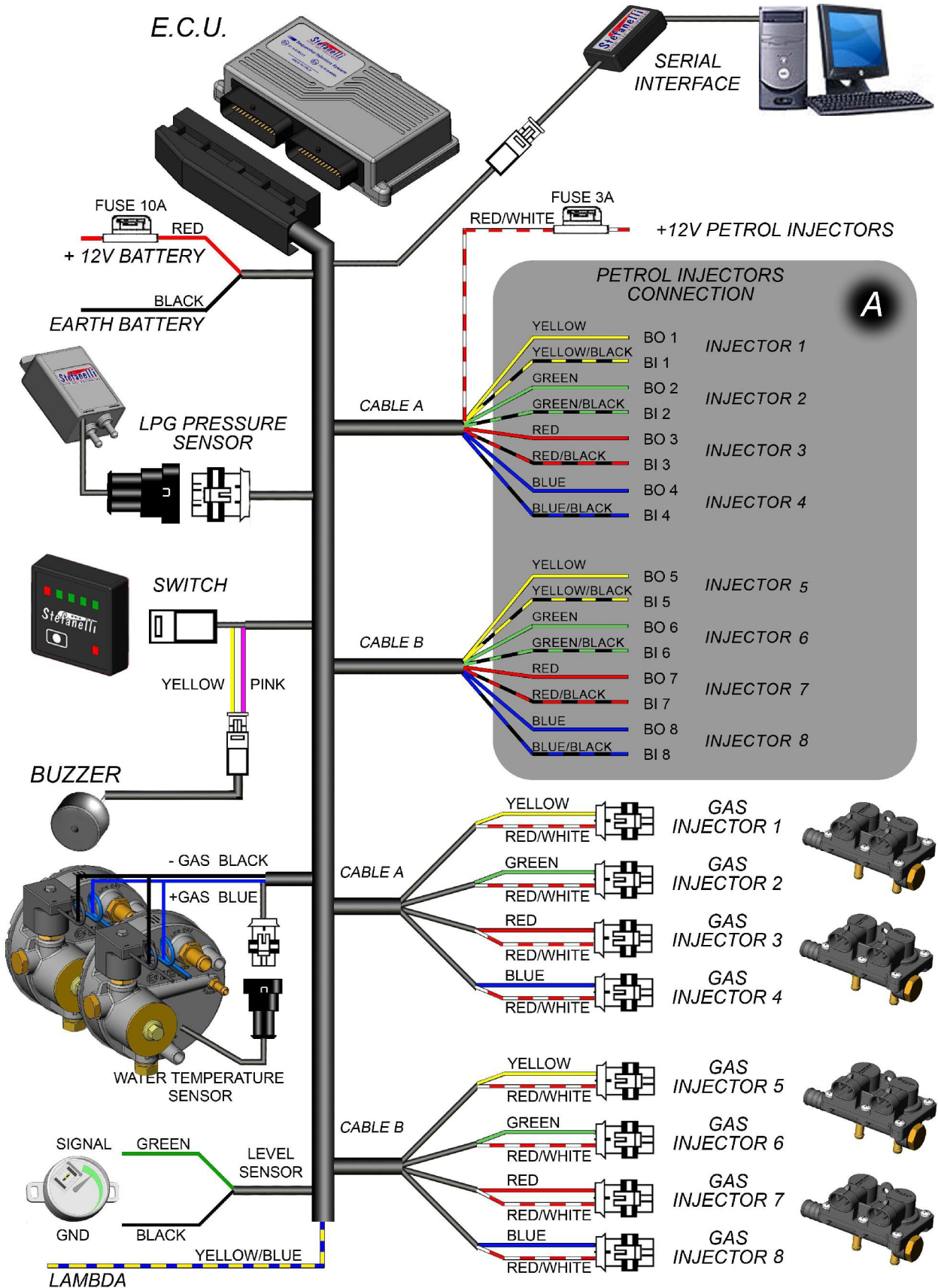

PETROL INJECTORS CONNECTION

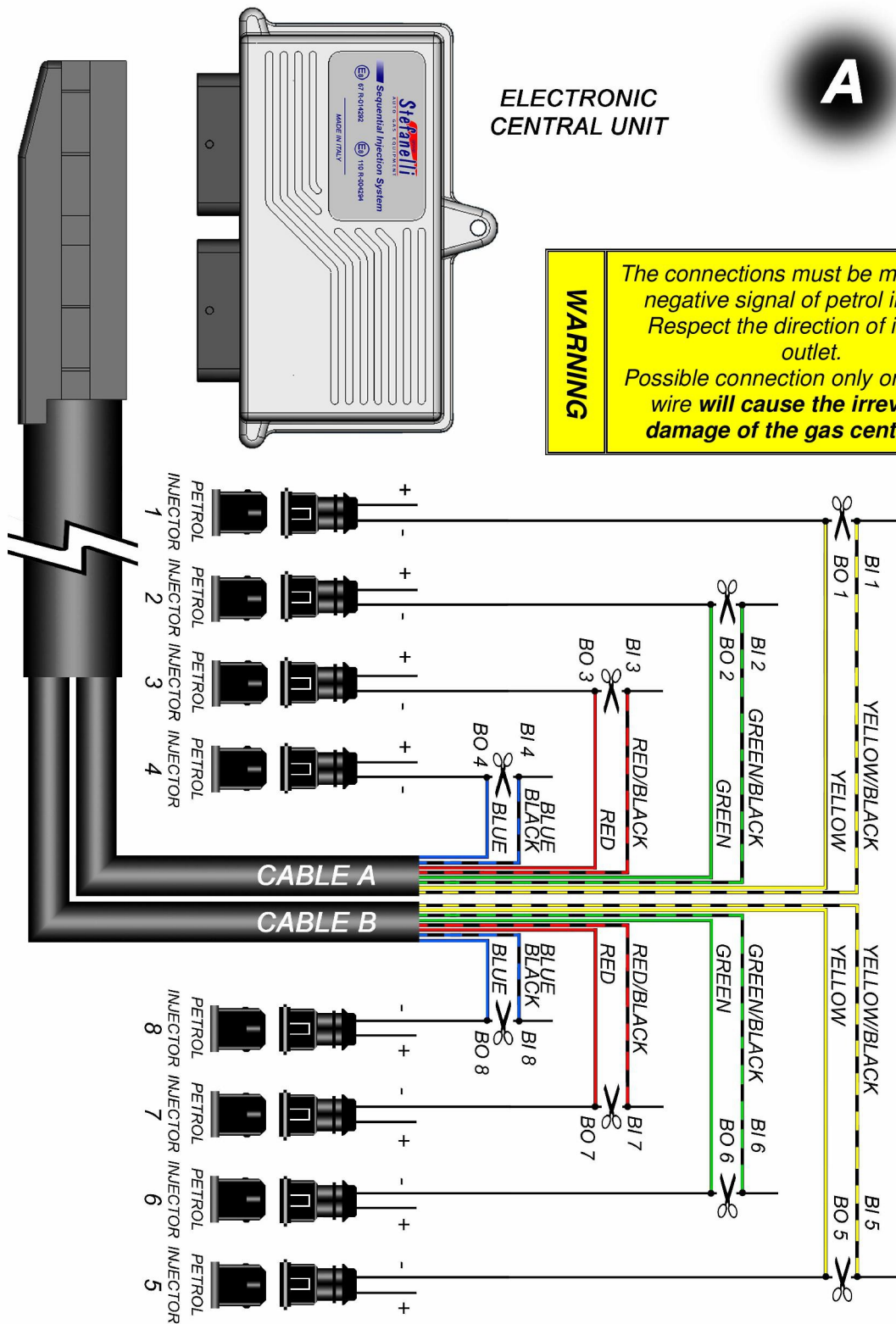

**ELECTRONIC
CENTRAL UNIT**

A

WARNING

The connections must be made on the negative signal of petrol injectors. Respect the direction of inlet and outlet.

Possible connection only one positive wire **will cause the irreversible damage of the gas central unit.**

INJECTION KIT SIS 8 CYLINDERS – 2 REDUCER GEO 110 M

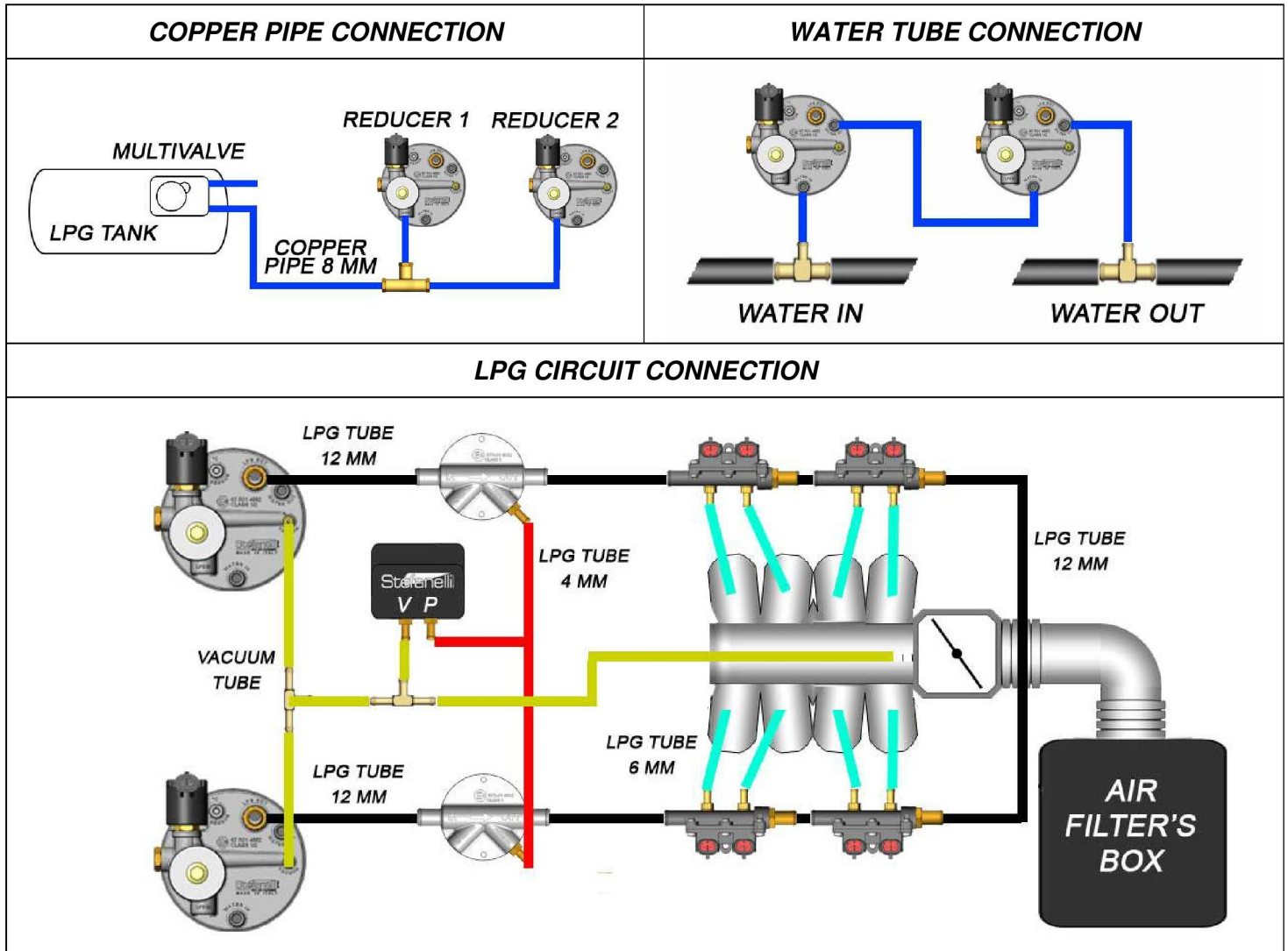

ELECTRO-INJECTORS REFERENCE TABLE

The following is the electro-injectors table which allows you to choose the electro-injectors to use for the SIS installation. The electro-injectors have been divided according to the power/cylinder. In order to determine the electro-injectors to use, proceed as follows:

- A) Determine the power of the vehicle (in the table the power is expressed both in Kilowatt and in horsepower /hp/)
- B) Divide the above-mentioned power by the number of cylinders of the vehicle
- C) Once you have obtained the result of the power divided by cylinder, control which sector of the table the result corresponds to
- D) Install the electro-injectors corresponding to this sector

		POWER BY CYLINDER		ELECTRO-INJECTOR
		Kw	hp	
		9,5 ÷ 16,5	13 ÷ 22	GREEN
		16,75 ÷ 21,25	23 ÷ 29	WHITE
		21,5 ÷ 30	29,5 ÷ 41	RED
Example		A. BMW 540i V8 4.0 – 225 kW B. $225 \div 8 = 28.125$ kW C. Corresponds to the RED sector in the table D. Install the RED electro-injectors		

REDUCER PRESSURE REGULATION

POWER		RELATIVE PRESSURE (bar)	REDUCER
<i>kW</i>	<i>hp</i>	<i>is intended whit engine on</i>	
Until to 73.5	Until to 100	0.7 ÷ 0.9	GEO 110 "N"
73.5 ÷ 110	100 ÷ 150	Max 1.25	GEO 110 "N"
110 ÷ 160	150 ÷ 220	Max 1.5	GEO 110 "M"